

(No Model.)

J. F. BOGAN

DEVICE FOR REDUCING THE DIAMETER OF METAL RODS OR WIRES.

No. 313,283.

Patented Mar. 3, 1885.

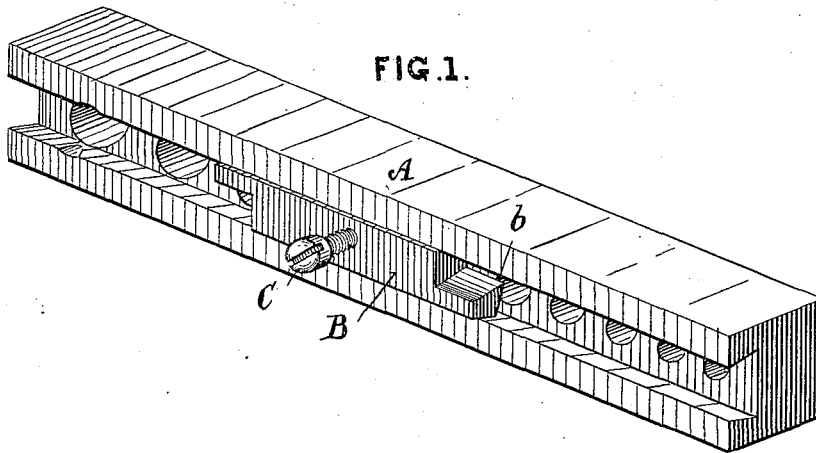

FIG. 2.

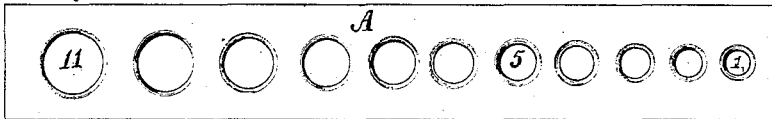

FIG. 3.

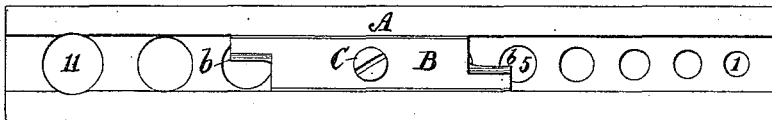

FIG. 9.

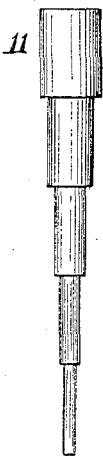

FIG. 4.

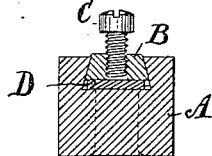

FIG. 10.



FIG. 5.



FIG. 6.

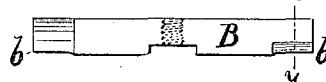

FIG. 8.

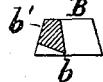

FIG. 7.



Witnesses.  
 E. Blanta.  
 - J. H. Moore

Inventor.  
 Jas. F. Bogan  
 by J. H. Adams  
 Attorney.

# UNITED STATES PATENT OFFICE.

JAMES F. BOGAN, OF EAST BOSTON, MASS., ASSIGNOR TO GEORGE E. MARVIN, OF BOSTON, RONELLO F. PRATT, OF EVERETT, AND WILLIAM E. CARLETON, OF CHARLESTOWN, MASS.

DEVICE FOR REDUCING THE DIAMETER OF METAL RODS OR WIRE.

SPECIFICATION forming part of Letters Patent No. 313,293, dated March 3, 1885.

Application filed March 15, 1884. (No model.)

*To all whom it may concern:*

Be it known that I, JAMES F. BOGAN, a citizen of the United States, residing at East Boston, in the county of Suffolk and State of Massachusetts, have invented a new and useful Improvement in Milling Devices, of which the following is a specification.

My invention relates to an improved means for reducing the diameter of portions of a metal rod or wire; and it consists of an elongated block of metal having a series of holes extending the whole length of the block, the hole at one end being of the smallest required size, and the holes increasing in size or diameter throughout the length of the block. In one side of the block is a dovetailed groove extending the whole length of the block, in which is fitted to slide a metal block or bar having a cutting-edge at each end, which cutting-edge is made to project over a portion of one of the holes in which is inserted the wire to be reduced, the sliding block being held in position in the groove by means of a screw. The wire or rod is secured in a lathe, and the device is held in the hand while the wire is spun through the proper hole.

Referring to the accompanying drawings, Figure 1 is a perspective view of my device. Fig. 2 is a front view of the same. Fig. 3 is a rear view, and Fig. 4 is a transverse section. Figs. 5 to 8 are detail views of the sliding cutter-bar. Figs. 9 and 10 represent rods or wires of different sizes as reduced by the cutters.

A represents an elongated rectangular block of metal pierced with a series of holes, the hole at one end being of a size to fit the smallest wire required to be operated upon, and the holes increasing in size toward the opposite end of the block to fit wires of different sizes. Fig. 2 represents the front or face side of the block A, that being the side which the wire to be operated upon enters.

In the rear of the block A is a groove extending the whole length of the block, and adapted to receive a sliding dovetailed bar or block, B, which may be a third, more or less, of the length of the block A.

On each end of the bar B is formed a cutter,

*b*, as shown, the portions forming the cutting-edges being about one-half the width of the bar B.

Through the bar B passes a screw, C, by which the said bar is held securely in place.

In a recess on the under side of the cutter B is fitted a thin plate, D, against which the screw C bears, and is designed to cover a hole in case the cutter-bar is set so that the screw comes over a hole.

The form of the cutters is shown in Fig. 8, which is a section on the line *xy* of Fig. 6.

In operation the wire to be milled or reduced in diameter in part is first secured in a lathe. The end of the wire is then passed into the hole of the size which the wire fits. The cutter *b* at one end of the bar B is then set to project over a portion of one of the holes, as shown, for instance, in the hole marked 5, so as to cut and reduce the diameter of the wire as required. Should it be desirable to make portions of the same wire of different diameters, as shown in Figs. 9 and 10, the cutter is farther advanced over the hole, when the size of the wire will be still further reduced, and so the operation may be continued as required.

The device can be held in the hand while the wire or stock is spun in the lathe.

In the ordinary method of milling wire it is necessary to use a different cutting-tool in reducing the size of portions of the wire, while in my improved device the cutter can at once be set to cut the different portions of the same hole in the block.

What I claim as my invention is—

1. A milling device consisting of the longitudinally-grooved block A, having a series of perforations of different sizes formed in the grooved portion thereof, and the adjustable cutter-bar B, secured in the groove and adapted to reduce the diameter of a wire passed through one of said perforations, substantially as described.

2. The combination of the longitudinally grooved and perforated block A, the sliding cutter-bar B, provided with a cutting-edge, *b*, at each end, and the screw C, for adjustably securing the cutter-bar in the grooved por-

tion of the block, substantially as shown and described.

3. The combination of the grooved and perforated block A, the cutter-bar B, the plate D,  
5 and screw C, substantially as and for the purpose set forth.

In testimony whereof I have signed my name

to this specification in the presence of two subscribing witnesses.

JAMES F. BOGAN.

Witnesses:

JOS. H. ADAMS,  
E. PLANTA.